

INDUSTRIAS ELECTROMECHANICAS GH, S.A.

GH

CRANES & COMPONENTS

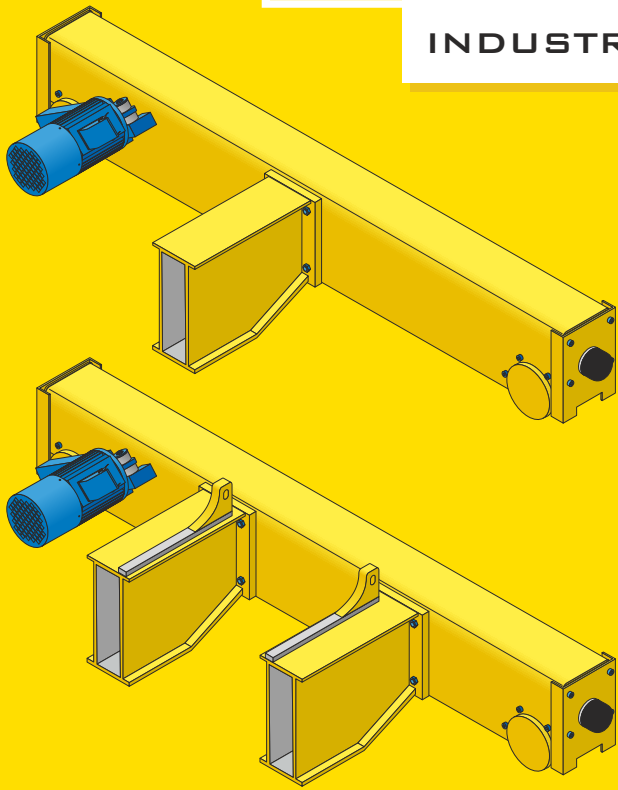

KOMPONENTY SUWNICY



TABELA DOBORU KOŁA *



* Podana informacja jest przybliżona. Ostateczna średnica koła zależy od prędkości, warunków pracy i szerokości szyny.

KOMPONENTY JAZDY SUWNICY

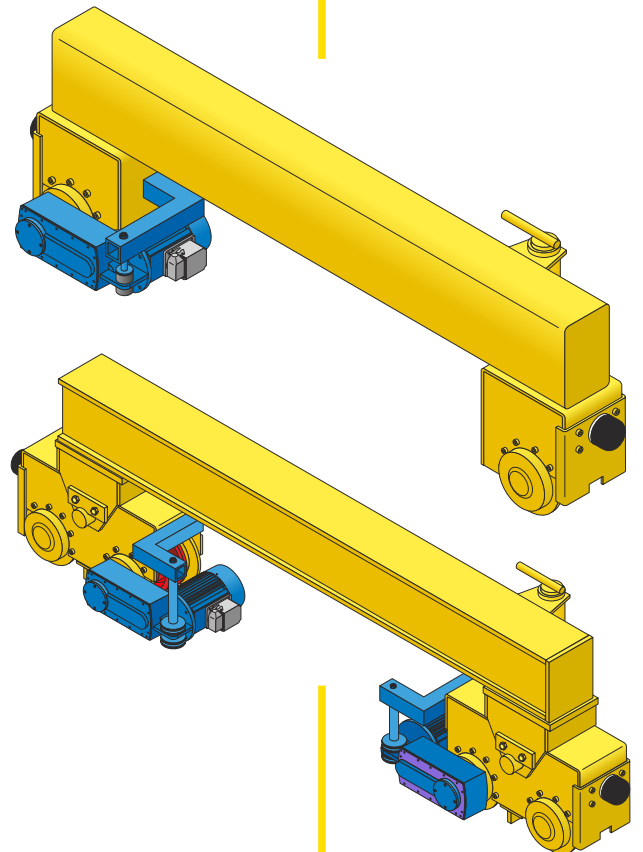
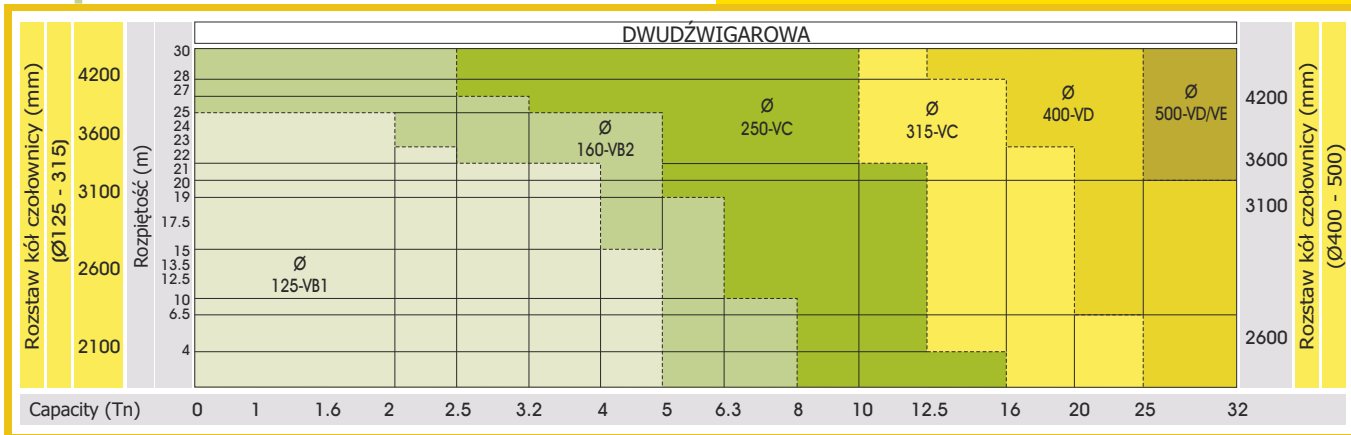
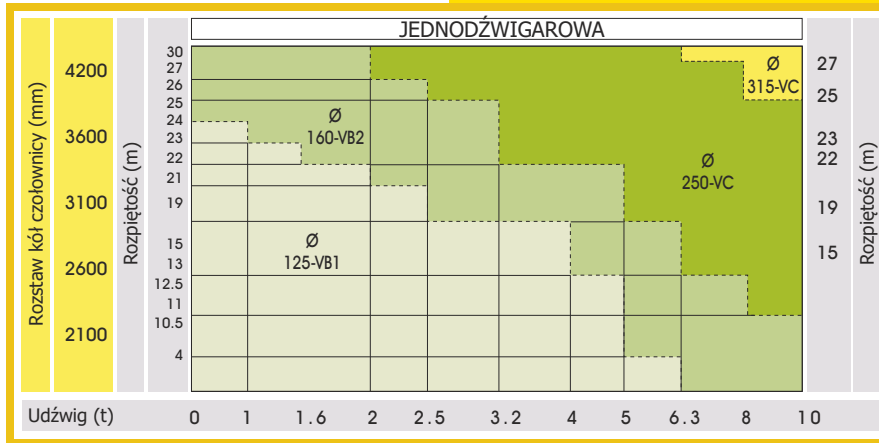
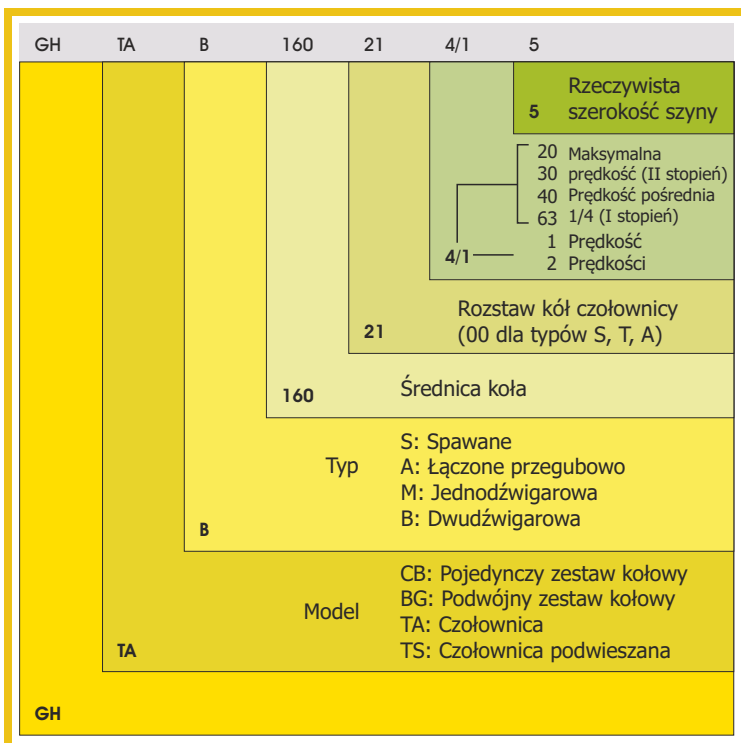

CZOŁOWNICE STANDARDOWE

Średnica koła	Typ przekładni	Możliwe prędkości w m/min.						
		10	15	20	25	30	40	60
125	RFS/125	✗	✗	✗				
160	RFS/160							
250	RFS/250						3T	
315	RFS/315							
400	RFS/400							
500	RFS/500	✗		4T				
630	RFS/630	✗						

CZOŁOWNICE PODWIESZANE

Średnica koła	Typ przekładni	Możliwe prędkości w m/min.					
		10	15	20	25	30	40
125	RFS/125						✗
160	RFS/160						✗
200	RFS/250			3T			✗
250							✗

PRZEKŁADNIE JAZDY

Zaprojektowane specjalnie przez GH używane do jazdy suwnicy i wciągnika.

Stopniowe przyspieszanie, sprawne hamulce, przy minimalnym hałasie.

Koła jezdne z podwójnymi obrzeżami z zamontowanymi łożyskami. Napęd kół jest przenoszony przez wielowypustowy wałek.

TRZYSTOPNIOWA PRZEKŁADNIA

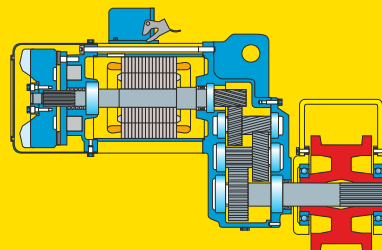
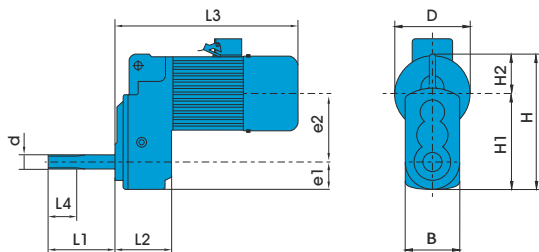

Waga, Kg	Typ silnika	Typ przekładni	Moc silnika (Kw), F = 50 Hz		Ød mm.	L1 mm.	L2 mm.	L3 mm.	L4 mm.	e1 mm.	e2 mm.	B mm.	Ø D mm.	H1 mm.	H2 mm.	H mm.
			3000 Var	3000/750												
24	VB1-60	RFS / 125-3T	0,85	0.40/0.10	34,9	152	112	389	60	60	134,2	120	157,5	194,2	78	273,2
32	VB2-60	RFS / 160-3T	0,85		34,9	166	134	448,5	70	67	168,25	134	157,5	235,25	90	325,25
34	VB2-100		0,75/0.18													
50	VC-85	RFS / 250-3T	1,5		49,9	240	146	492	60	90	218,05	180	218	308,05	109	417,05
54	VC-110		2,5	1.5/0.37												
50	VC-85	RFS / 315-3T	1,5		49,9	250	146	492	60	90	218,05	180	218	308,05	109	417,05
54	VC-110		2,5	1.5/0.37												
150	VD-110	RFS / 400-3T	5	3/0.75	64,9	316	235	592	65	130	323,7	250	265	453,7	135	588,7
150	VD-110	RFS / 500-3T	5	3/0.75	79,9	332	235	592	65	130	323,7	250	265	453,7	135	588,7
205	VE-110	RFS / 500-3T	7,5	5.1/1.3	79,9	332	235	672	65	130	323,7	250	327	453,7	135	617
320	VE-110	RFS / 630-3T	7,5	5.1/1.3	89,9	399	262	700	55	200	440,9	400	327	640,9	166	806,9

CZTEROSTOPNIOWA PRZEKŁADNIA

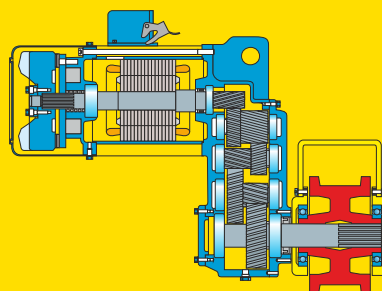
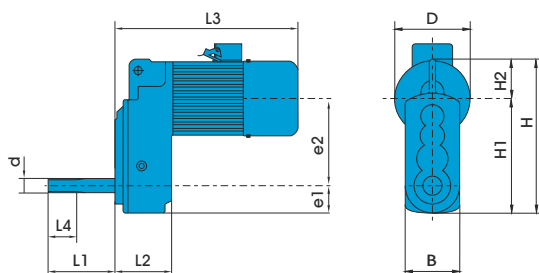

Waga, Kg	Typ silnika	Typ przekładni	Moc silnika (Kw), F = 50 Hz		Ød mm.	L1 mm.	L2 mm.	L3 mm.	L4 mm.	e1 mm.	e2 mm.	B mm.	Ø D mm.	H1 mm.	H2 mm.	H mm.
			3000 Var	3000/750												
36	VB2-60	RFS / 160-4T	0,85		34,9	166	154	463	70	75	240,8	150	157,5	315,8	90	405,8
38	VB2-100		0,75/0.18													
56	VC-85	RFS / 250-4T	1,5		49,9	240	160,5	495	60	100	289	200	218	389	109	498
60	VC-110		2,5	1.5/0.37												
56	VC-85	RFS / 315-4T	1,5		49,9	250	160,5	495	60	100	289	200	218	389	109	498
60	VC-110		2,5	1.5/0.37												
160	VD-110	RFS / 400-4T	5	3/0.75	64,9	316	235	592	65	145	447,7	290	265	592,7	135	727,7
160	VD-110	RFS / 500-4T	5	3/0,75	79,9	332	235	592	65	145	447,7	290	265	592,7	135	727,7
215	VE-110	RFS / 500-4T	7,5	5.1/1.3	79,9	332	235	672	65	145	447,7	290	327	592,7	135	756

CZOŁOWNICE DO JEDNODŹWIGAROWYCH I DWUDŹWIGAROWYCH SUWNIC

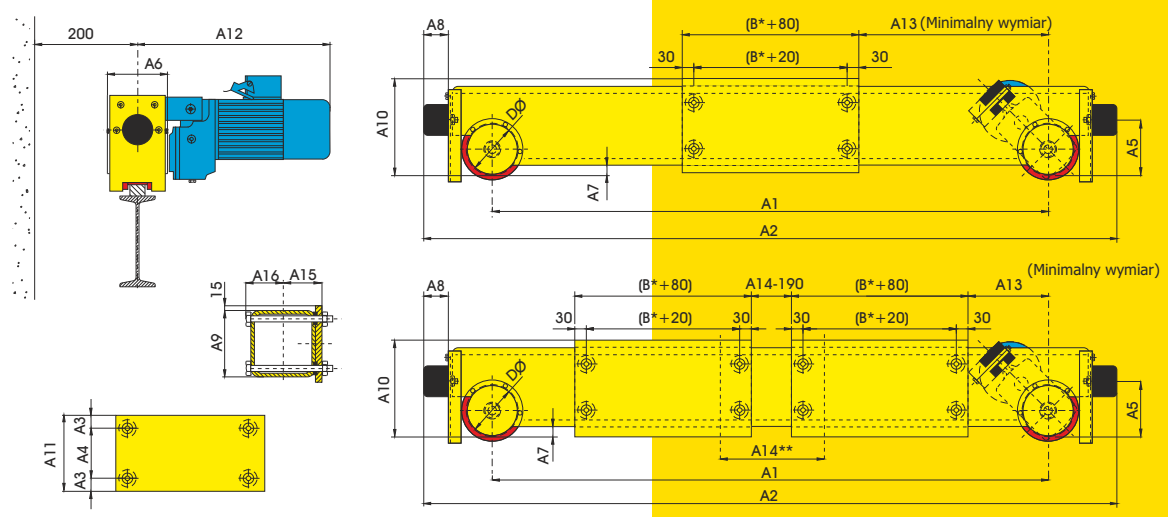

DØ	A1	A2	A3	A4	A5	A6	A7	A8	A9	A10	A11	A12	A13	Jednodźwigarowa			Dwudźwigarowa		
														A14	A15	A15	A16	Waga (Kg)	Waga (Kg)
100	1600	1932			118									330					
	2100	2432			118									710					
	2600	2932	50	130	118	152	13	58	200	228	230	469	185	710	80	80	---		
	3100	3432			160									1010					
	3600	3932			160									1310					
125	1600	1960												--				135	--
	2100	2460												900				160	160
	2600	2960	50	130	125	171	20	80	200	235	230	475	185	1200	97 (20)	97	103	185	185
	3100	3460												1200	107 (30)			210	210
	3600	3960												1500				235	235
160	1600	2035												--				175	--
	2100	2535												900				205	205
	2600	3035												1200				235	235
	3100	3535	50	180	160	175	37.5	97	250	302.5	280	536	205 (3T) 295 (4T)	1200	107	97	103	265	265
	3600	4035												1500				295	295
	4200	4635												1800				330	330

* Wymiar «B» zależy od szerokości pasa dźwigara. ** Wymiar A14 zależy od rozpiętości wózka.

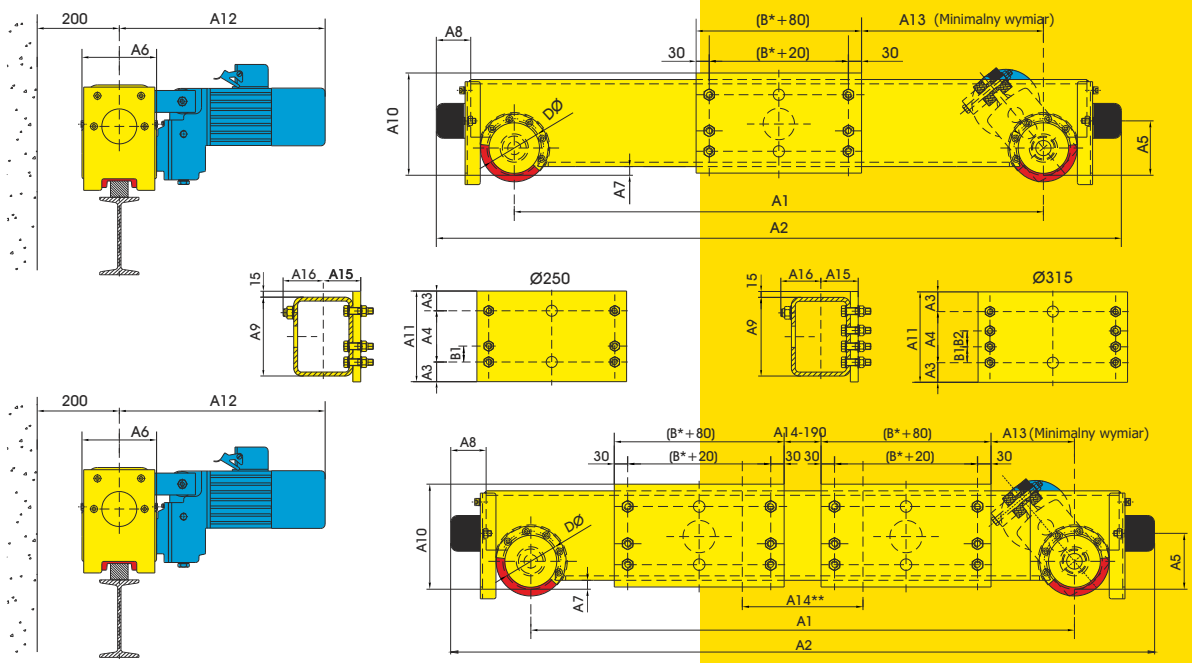

DØ	A1	A2	A3	A4	A5	A6	A7	A8	A9	A10	A11	A12	A13	A14	Jednodźwigarowa			Dwudźwigarowa			
															A15	A15	A16	B1	B2	Waga (Kg)	Waga (Kg)
250	2100	2665												900				335	335		
	2600	3165												1200				380	380		
	3100	3665	65	200	250	258	30	117	300	345	330	621	295 (3T) 375 (4T)	1200	120 (20)	120	128	60	--	425	425
	3600	4165												1500	130 (30)			470	470		
	4200	4765												1800				525	525		
315	2100	2725												900				505	505		
	2600	3225												1200				565	565		
	3100	3725	70	290	315	268	62.5	117	400	477.5	430	626	205 (3T) 310 (4T)	1200	130	120	128	65	65		
	3600	4225												1500				685	685		
	4200	4825												1800				760	760		

* Wymiar «B» zależy od szerokości pasa dźwigara. ** Wymiar A14 zależy od rozpiętości wózka.

CZOŁOWNICE DLA SUWNIC DWUDŹWIGAROWYCH

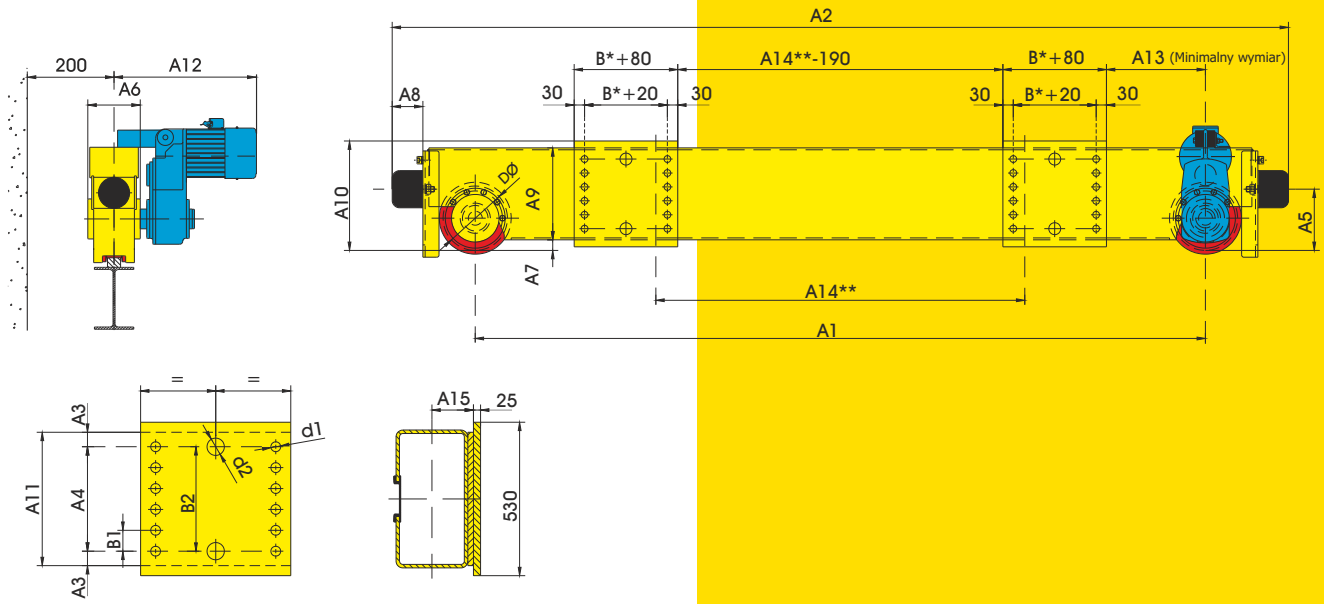

DØ	A1	A2	A3	A4	A5	A6	A7	A8	A9	A10	A11	A12	A13	A14	A15	B1	B2	Ød1	Ød2	Waga (Kg)
400	3100	3900	50	390	335	285	50	130	500	565	490	785	275	1500	120	78	390	24	40	930
	3600	4400												1500						990
	4200	5000												1800						1065
500	3100	4070	40	410	385	301	100	165	500	615	490	795	320	1500	120	82	380	26	70	1220
	3600	4570												1500						1290
	4200	5170												1800						1395

* Wymiar «B» zależny od szerokości pasa dźwigara. ** Wymiar A14 zależny od rozpiętości wózka.

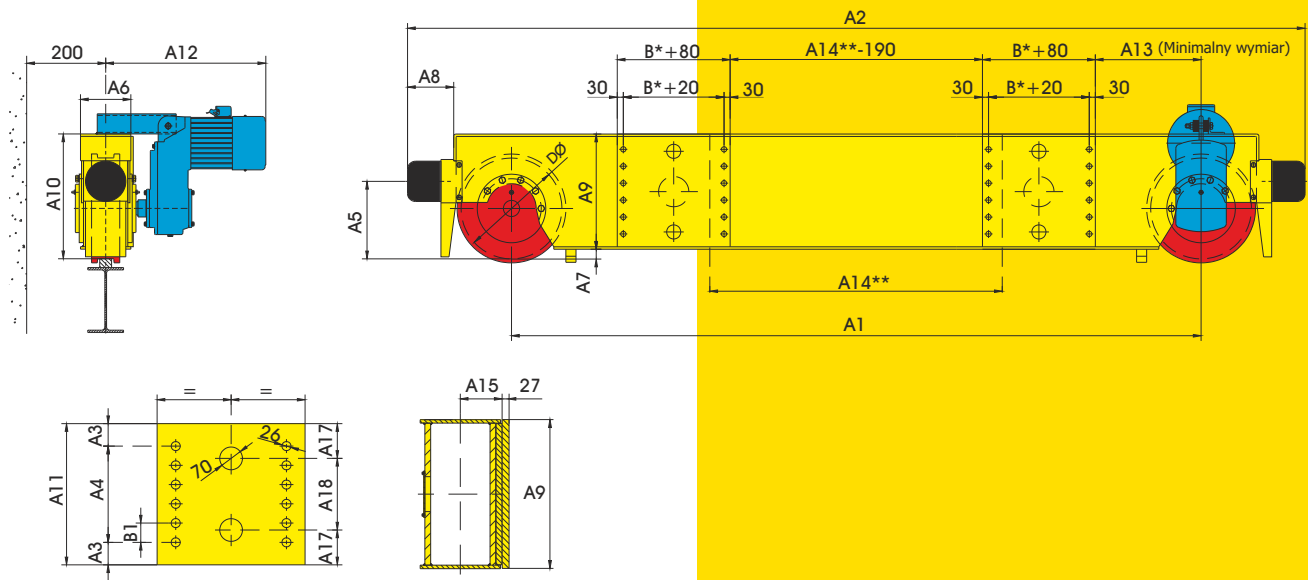

DØ	A1	A2	A3	A4	A5	A6	A7	A8	A9	A10	A11	A12	A13	A14	A15	A17	A18	B1	Waga (Kg)
500	3100	3900	66,5	410	385	301	48	230	571	619	543	795	320	1500	137	81,5	380	82	1490
	3600	4400												1500					1590
	4200	5000												1800					1700
630	3100	4070	33	540	495	383	45	268	640	685	606	930	390	1500	180	133	340	90	2435
	3600	4570												1500					2595
	4200	5170												1800					2790

* Wymiar «B» zależny od szerokości pasa dźwigara. ** Wymiar A14 zależny od rozpiętości wózka.

CZOŁOWNICE DLA SUWNIC PODWIESZANYCH

MODEL JEDNODŹWIGAROWY TS - M

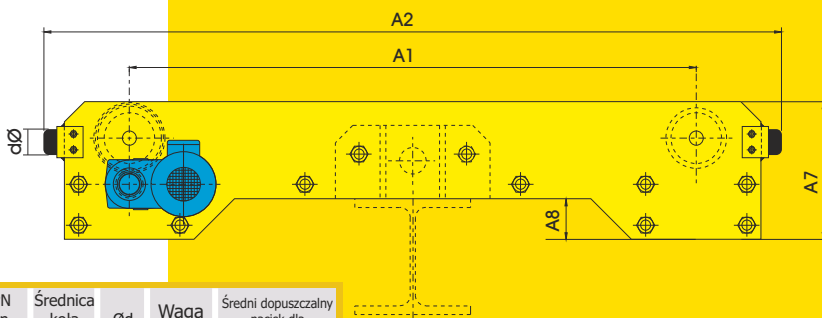

Rozpiętość m	A1 mm.	A2 mm.	A4 mm.	A5 mm.	A6 min. mm.	A7 mm.	A8 mm.	IPN min. mm.	Średnica koła mm	Ød mm	Waga Kg	Średni dopuszczalny nacisk dla pary kół (daN)
9 15	1200 2100	1600 2500	66	472	160	340	100	180	125	63	205 260	3600
9 15	1200 2100	1640 2540	71	522	198	390	105	220	160	63	275 360	5300
15 22	2100 3100	2630 3630	85	595	245	440	110	260	200	100	460 565	9300
15 22	2100 3100	2710 3710	95	595	287	540	130	320	250	100	730 885	13300

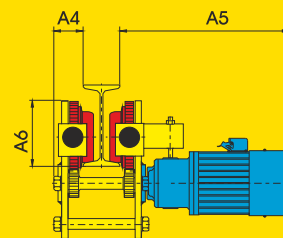

Notatka: Czołownice o wymiarze A1 mniejszym niż 2100 są dostępne tylko jako oddzielne pozycje.

MODEL DWUDŹWIGAROWY TS - B

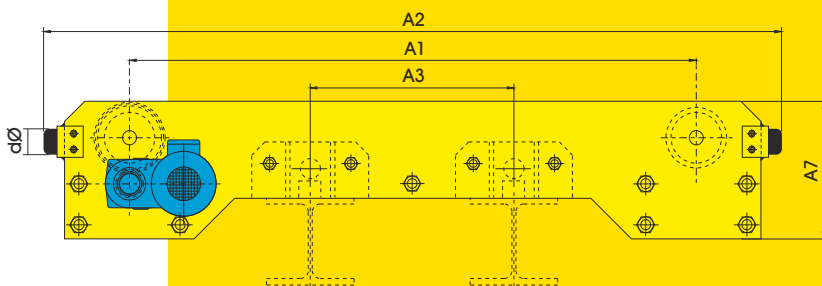

Rozpiętość m	A1 mm.	A2 mm.	A3 mm.	A4 mm.	A5 mm.	A6 min. mm.	A7 mm.	A8 mm.	IPN min. mm.	Średnica koła mm	Ød mm	Waga Kg	Średni dopuszczalny nacisk dla pary kół (daN)
9 15	1600 2100	2000 2500	900 900	66	472	160	340	100	180	125	63	230 260	3600
9 15	1600 2100	2040 2540	900 900	71	522	198	390	105	220	160	63	310 360	5300
15 22	2100 3100	2630 3630	900 1200	85	595	245	440	110	260	200	100	460 565	9300
15 22	2100 3100	2710 3710	900 1200	95	595	287	540	130	320	250	100	730 885	13300

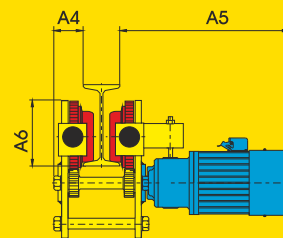

Notatka: Czołownice o wymiarze A1 mniejszym niż 2100 są dostępne tylko jako oddzielne pozycje.

POJEDYNCZE ZESTAWY KOŁOWE

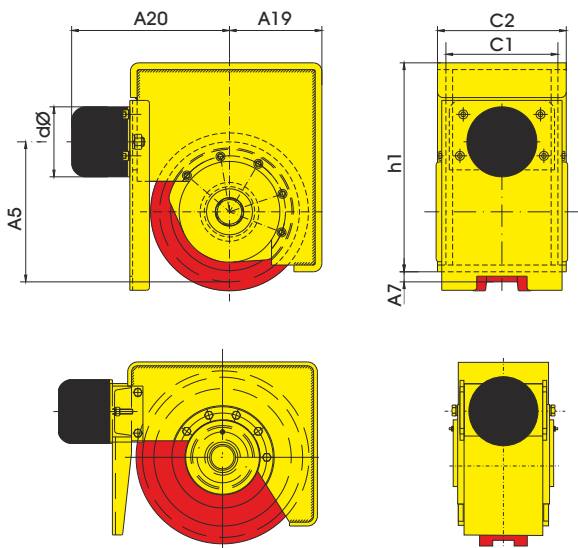

Pojedyncze zestawy kołowe do spawania
Ø125 Ø160 Ø250 Ø315 Ø400 Ø500

	Średnica koła	Wymiary							Ød
		C1	C2	H1	A5	A7	A19	A20	
Przyspawane pojedyncze zestawy kołowe	125	150	180	205	125	10	100	179	80
	160	150	180	255	160	27.5	120	217	100
	250	200	230	373	250	18	165	282	125
	315	200	230	373	305	50.5	195	312	125
	400	225	250	506	335	38	262	400	160
	500	220	250	546	385	48	312	486	200
	630	305	345	645	495	45	373	645	250

Pojedyncze zestawy kołowe do spawania Ø 630

POJEDYNCZE ZESTAWY KOŁOWE DO SUWNIC BRAMOWYCH

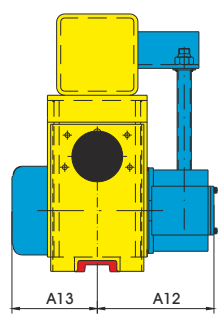
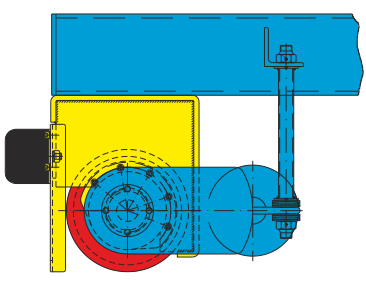

Średnica koła	Typ przekładni	Typ silnika	Wymiary A12	Wymiary A13
160	RFS/160-4T	VB2	234	222
250	RFS/250-4T	VC	282	215
315	RFS/315-4T	VC	287	210
400	RFS/400-4T	VD	420	172
500	RFS/500-4T	VD	428	165
630	RFS/630-3T	VE	928	192

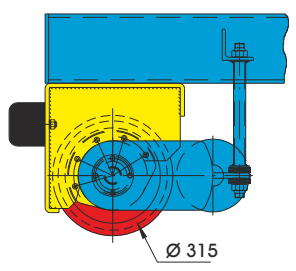

Średni dopuszczalny nacisk na koło GGG70 (daN) Zgodnie z FEM/UNE grupa M4						
Średnica koła	Prędkość jazdy wciągnika w m/min	Szerokość szyny w K (mm)				
		40	50	60	70	80
125	20	4500	5000			
	40	3600	4000			
	63	3200	3400			
160	20	5900	7000	8300		
	40	5000	6200	7400		
	63	4400	5400	6400		
250	20	9800	12200	14400		
	40	8900	11100	13400		
	63	8000	10000	12000		
315	20	12700	15800	18600	18600	
	40	11600	14500	17400	18600	
	63	10900	13500	16200	17600	
400	20	16500	20700	24800	28900	30000
	40	15200	18900	22700	26500	30000
	63	14200	17800	21400	24900	27800
500	20		26200	31500	36800	40000
	40		24400	29300	34200	39000
	63		23000	27600	32200	36800
630	20			40500	47200	52800
	40			38000	44300	50600
	63			35800	41800	47700

Wskaźnik obciążenia Rmin/Rmax = 0,35
Minimalny gatunek szyny jezdnej S355 (St52)

PODWÓJNE ZESTAWY KOŁOWE DLA SUWNIC BRAMOWYCH

DIN	Typ szyny	Wymiary	
		L	K
536	A 45	45	37
	A 55	55	45
	A 65	65	53
	A 75	75	59
	A 100	100	80
	A 120	120	100

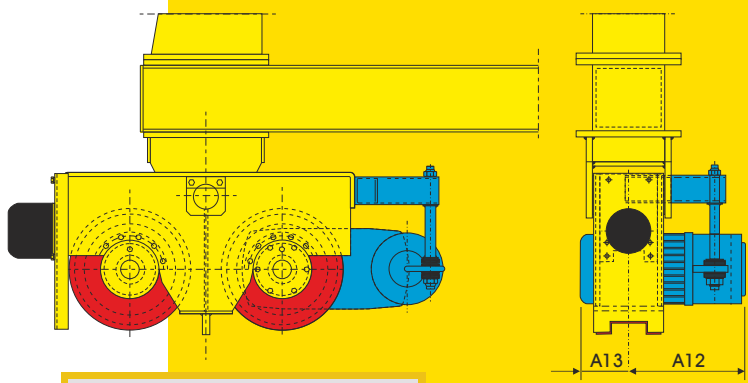

Podwójny zestaw kołowy Ø 315 - 400

Szyna typu Burbach (dźwignicowa): $k = L - 2r$
 Szyna typu kolejowego: $k = L - 4 / 3r$
 Szyna kwadratowa: $k = L$

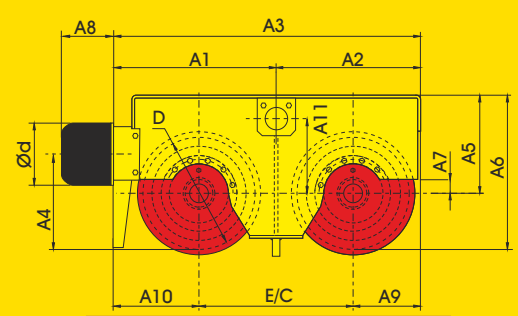
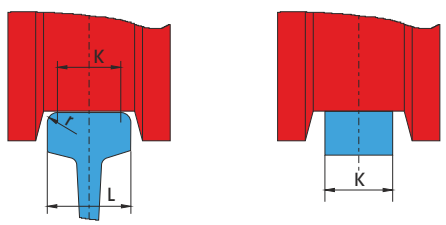

Podwójny zestaw kołowy Ø 500 - 630

Średnica koła	E/C	D	A1	A2	A3	A4	A5	A6	A7	A8	A9	A10	A11	A12	A13	Ød
315	500	315	458	457	915	315	266	423,5	42,5	131	207	208	184	287	210	160
400	550	400	545	537	1082	335	344	544	50	166	262	270	262	420	172	200
500	650	500	675	612	1287	385	369	619	30	208	287	350	277	428	165	250
630	800	630	848	773	1621	495	385	700	65	265	373	448	278	928	192	250

KOMPONENTY ELEKTRYCZNE

- | | |
|--|----------------------------------|
| 1. Wyłącznik krańcowy podnoszenia | 13. Uchwyty kablowe |
| 2. Ogranicznik udźwigu | 14. Łącznik przewodniczy |
| 3. Złącze kasyty sterowniczej | 15. Uchwyt przewodniczy |
| 4. Odbój wciągnika | 16. Zacisk końcowy |
| 5. Prowadnica systemu zasilania jazdy wciągnika i kasyty | 17. Wózki kablowe |
| 6. Złącze wielopinowe silnika | 18. Zdalne sterowanie |
| 7. Ramię odbieraka prądowego | 19. Wspornik przewodniczy |
| 8. Łącznik krańcowy jazdy wciągnika | 20. Prowadzenie kabla |
| 9. Łącznik krańcowy jazdy suwnicy | 21. Szafa elektryczna suwnicy |
| 10. Krzywka łącznika krańcowego jazdy wciągnika | 21A. Szafa elektryczna wciągnika |
| 11. Ramię prowadzące | 22. Wspornik szafy elektrycznej |
| 12. Blokada firany | 23. Szyna jezdnia wciągnika |

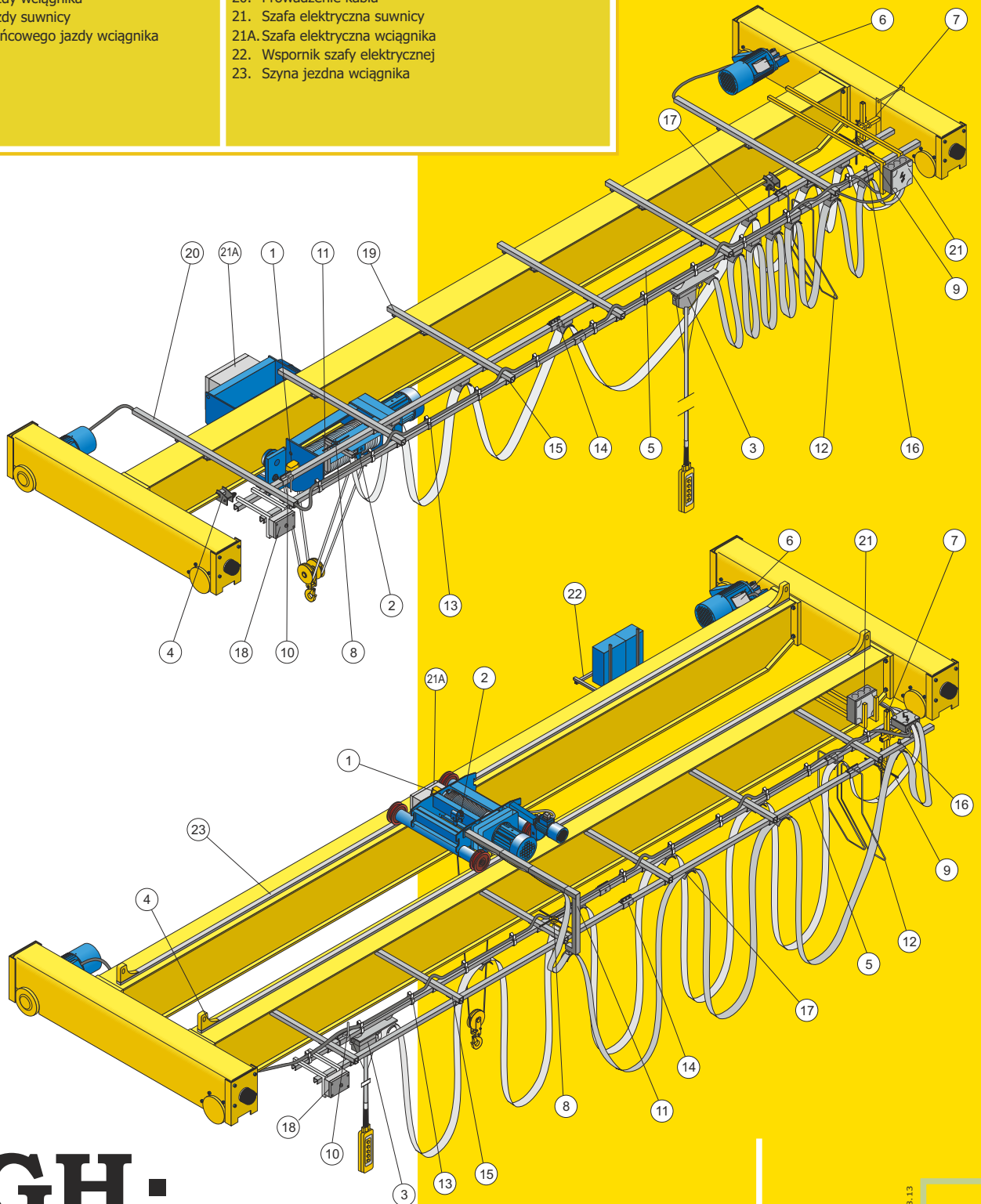

GH

CRANES & COMPONENTS

APDO. 27 - Bº SALBATORE
20200 BEASAIN (GIPUZKOA) SPAIN
TEL: +34 943 805 660
FAX: +34 943 888 721
E-MAIL: GHSA@GHSA.COM
WWW.GHCRANES.COM

GH CRANES SP. Z O.O.

UL. GÓRNICZA 2B
42-100 KŁODBUK
TEL: (+48) 34 359 73 17
FAX: (+48) 34 359 84 10
E-MAIL: INTERTECH@GHSA.PL
WWW.GHSA.PL

500/08.13

Anfora.net